



## INTERNATIONAL JOURNAL OF ENGINEERING SCIENCES & RESEARCH TECHNOLOGY

### Microcontroller Based Gesture Controlled Wheelchair Using Accelerometer

Manisha Chahal, B. Anil Kumar

School of EEE, Lingaya's University, India

[Chahalmanisha25@gmail.com](mailto:Chahalmanisha25@gmail.com)

---

#### Abstract

“Speech” and “gestures” are the expressions, which are mostly used in communication between human beings and for Human Computer Interaction (HCI). Recent development promises a wide scope in developing smart control systems. We present an integrated approach to real time detection, gesture based data glove approach which controls the wheelchair using hand movements. The paper proposed a microcontroller based system to control the wheelchair using low-cost and small 3-axis wireless accelerometers. The system is divided into two main components: Gesture recognition module with Micro-electromechanical systems (MEMS) sensor and wheelchair control. In the gesture recognition module the heart of the system is microcontroller. The MEMS sensor which is connected to hand, is an 3-axis accelerometer with digital output (I2C) that senses the angle of the hand, i.e. according to the tilt of hand it gives voltages to microcontroller. The wheelchair control unit is controlled using PC89C52 controller. The four proposed movements that achieved: are stop, backward, forward, left and right. Finally, the results of some tests performed with the controlled system are presented and discussed.

**Keywords:** Hand gesture recognition, posture, MEMS Sensor, Microcontroller, GRS, Human Robot Interface.

---

#### Introduction

Today's modern and tech savvy world comprises of a large variety of people. Some of them depend on others for their living. But in today's fast world, everyone is busy and there are less people to care for the increasing number of elderly and the physically challenged people. Also these people find it tough to even navigate inside the home without external aids. The elderly people find automated wheelchairs as an easy way for locomotion. Having known about these facts, our aim was to bring an automated control system which can be used by both the elderly and the physically challenged people in a user friendly manner using hand gestures for operation.

In biomedical sector, a wheelchair is an important device because of the recent shift in the industrial populations. The demand of the physically handicapped and the aged are ever rising. The present wheelchairs do not have integration of technologies for their working. It either requires constant monitoring by the helper or hence lot of effort. Traditional wheelchairs have some limitations in context ton flexibility, bulkiness and limited functions [1]. The recent developments in the robotics artificial intelligence or sensor technology

promises enormous scope for developing an advanced wheelchair. Some existing wheelchairs are fitted with pc for the gesture recognition or voice recognition [2]. But making use of the pc along with the chair makes it bulkier and increases complexity. This complexity is reduced by making use of the MEMS accelerometer [3-4], due to very compact and can be placed on the fingertip of the patients. And some other systems, which based on the same technique and use of similar kind of sensors are wired, which again increases the complexity of the system. They also limit the long range communication. This complexity is removed by using the RF transmission with high range frequency. Our approach allows the users to use human gestures of movement like hands and synchronize them with the movement of the wheelchair so that they can use it with comfort and ease on all kinds of terrains without the hurdle or cardiovascular problems or fatigue. In this project we are trying to include some sensors to develop an automated wheelchair which can help the patient to control the direction of the wheelchair based on gesture [5].

### Problem Definition

The objective of this project is to use the concept of gesture recognition to control a wheelchair (robot). By the use of latest emerging technology Gesture recognition the movement of the wheel chair will be controlled. The primary emphasis laid on the mechanism of GR Technology which is achieved by the help of accelerometer and its proposed mechanism. The four proposed movements that will be tried to achieve are backward, forward, stop, left and right.

### Related work

Gesture recognition based on data from an accelerometer is an emerging technique for gesture-based interaction after the rapid development of the MEMS technology. Accelerometers are embedded in most of the new generation personal electronic devices such as Apple iPhone , Nintendo wii mote which provide new possibilities for interaction in a wide range of applications, such as home appliances, in offices, in video games and most important in medical Centre. Gesture recognition has been extensively investigated . The majority of the past work has focused on detecting the contour of hand movement. Computer vision techniques in different forms have been extensively explored in this direction. As a recent example, the Wii remote has a “camera” (IR sensor) inside the remote and detects motion by tracking the relative movement of IR transmitters mounted on the display. It basically translates a “gesture” into “handwriting”, lending itself to a rich set of handwriting recognition techniques. In paper [6] by J.S. Kim, C.S. Lee, K.J. Song, B. Min, Z. Bien, a pattern recognizing algorithm has been used to study the features of hand. There are many papers where training of hands using a large database of near about 5000-10000 positive and negative images are considered. But this procedure is very tiring and time taking. In Paper [7] by Francisco Arce, José Mario García Valdez a three axis accelerometer has been used to read different types of hand gestures. But carrying extra circuitry on the hand involves attaching a number of accelerometers with the hand, this causes irritation to the user, there may be loose connection in the system which may result in abnormal outcomes. Hand gesture recognition using image processing algorithms many time involve use of color gloves. By tracking this color glove different hand gestures can be interpreted as described by Luigi Lambertil and Francesco Camastra in their paper [8]. Here they have modeled a color classifier performed by Learning Vector Quantization. In Paper [9] by Anala

Pandit, Dhairya Dand , Sisil Mehta , Shashank Sabesan , Ankit Daftery used a combination of accelerometer and gyroscope and the readings are taken into for analyzing the gesture. Here accelerometer is dedicated for collecting translational dynamic and static change in positional vector of hand and infer it to the movement of mouse whereas gyroscope has been used for rotation of virtual object. There are many papers where gestures are being analyzed using color gloves [10]. A data glove is a type of glove that contains fiber optics sensor embedded in it to recognize the fingers movement.

### Working model

Implementation of this proposed problem mainly involves two steps. They are gesture recognition and controlling direction of wheelchair using microcontroller based on the received gesture commands. The block diagram of the system is shown in Figure 1(a) Transmitter Block Diagram, (b) Receiver Block Diagram. As overviewed in the block diagram the hand gesture is sensed by accelerometer using the instrumented glove approach. The ADXL 330 accelerometer which convert the hand position into 3-Dimensional Output. The values obtained from the accelerometer are analog values which should be further converted into digital values so they can be used by the microcontroller. The accelerometer analog outputs are converted into digital with the help of ADC 0809. ADC converts the data from sensor and proceeds to the microcontroller (*P89V51RD2*) for further conversion and calibration. Microcontroller gets the data from the accelerometer and converted into ASCII code for LCD display. LCD display the X—Y—Z values and display the values on the LCD.

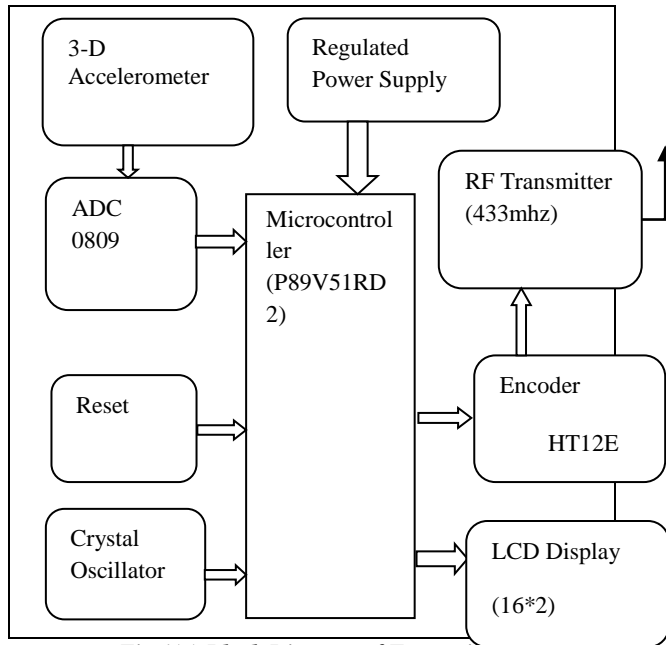

Fig 1(a) Block Diagram of Transmitter

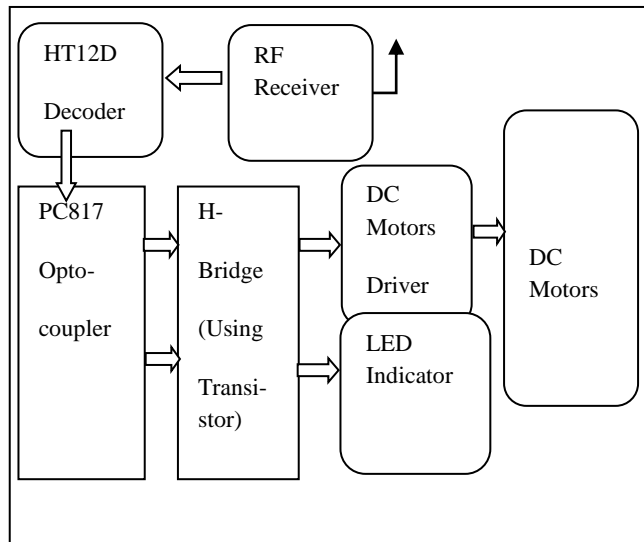

Fig 1(b) Block Diagram of Receiver

We use the readings obtained from accelerometer for wheel Chair movements. As the position of the hand changes, data from the accelerometer and microcontroller also changes automatically. We use HT12E encoder for serial communication. Data from the microcontroller is connected to the input pins of encoder and transmits via output pins of the encoder. Output from the encoder is connected to the RF transmitter module and transmit with frequency 433 Mhz. The RF receiver module sends it to the decoder which further decodes the signal and gives the signal to the optocoupler and H-Bridge circuitry which

drives the motors of wheel chair based on the hand gesture and same result shown by the LCD.

**Technology**

Gestures have recently become attractive for interaction with consumer electronics and mobile devices block diagram in fig. 1(a) by the use of gesture recognition technique via the accelerometer the movement of the wheel chair will be controlled. The primary goal of gesture recognition research is to create a system which can identify specific human gestures and use them to convey information or for device control. Gesture Recognition is the act of interpreting motions to determine such intent. There are different types of gestures such as hand, face (emotion), body gestures etc. To identify and recognize these gestures there are different ways of gesture recognition such as:

- 1)hand and arm gestures: recognition of hand poses, sign languages, and entertainment applications (allowing children to play and interact in virtual environments).
- 2)head and face gestures: Some examples are a) nodding or head shaking, b) direction of eye gaze, c) raising the eyebrows, d) opening and closing the mouth, e) winking, f) flaring the nostrils, e) looks of surprise, happiness, disgust, fear, sadness, and many others represent head and face gestures.
- 3)body gestures: involvement of full body motion, as in a) tracking movements of two people having a conversation, b) analyzing movements of a dancer against the music being played and the rhythm, c) recognizing human gaits for medical rehabilitation and athletic training.

**Gesture Recognition Approach**

For any system the first step is to collect the data necessary to accomplish a specific task. For hand posture and gesture recognition system different technologies are used for acquiring input data. Present technologies for recognizing gestures can be divided into vision based, instrumented (data) glove.

**Vision Based approaches**

In vision based methods the system requires only camera(s) to capture the image required for the natural interaction between human and computers and no extra devices are needed. Although these approaches are simple but a lot of gesture challenges are raised such as the complex background, lighting variation, and other skin color objects with the hand object, besides system requirements such as velocity, recognition time, robustness, and computational efficiency .[11]

**Instrumented Glove approaches**

Instrumented data glove approaches use sensor devices for capturing hand position, and motion. These approaches can easily provide exact coordinates of palm and finger’s location and orientation, and hand configurations .however these approaches require the user to be connected with the computer physically , which obstacle the ease of interaction between users and computers, besides the price of these devices are quite expensive it is inefficient for working in virtual reality .[12] Instrumented Glove based (smart glove) solutions can recognize very fine gestures, e.g., the finger movement and conformation but require the user to wear a glove tagged with multiple sensors to capture finger and hand motions in fine granularity. As a result, they are unfit for spontaneous interaction due to the high overhead of engagement.

| Parameter s     | Data-Glove based  | Vision based   |
|-----------------|---|--|
| Computing Power | computational power not an issue(less)                          | more computing power   |
| User Comfort    | quite cumbersome(wear a tracking device, glove)                 | complete freedom   |
| Hand Size       | problem with glove-based solutions(due to different hand sizes) | not an issue   |
| Calibration     | more critical   | Simple   |
| Portability     | Freely available (hand tracking is not involved)                | difficult (due to camera placement issues and computing power requirements ) |
| Cost            | Expensive(trackin g device)                                     | Inexpensive  |
| Noise           | bounded with data   | Minimal  |
| Accuracy        | high level  | high level   |

Table 1 Vision v/s Instrument Glove

**Sensing Device**

**Accelerometer**

Accelerometer-based gesture recognition has become increasingly popular over the last decade. The low-moderate cost and relative small size of the accelerometers make it an effective tool to detect and recognize human body gesture. We are using the Instrumented Glove based approach or Smart Glove using Accelerometer sensor for interfacing between Transmitter and Robot (GRS). Micro Electro Mechanical Systems (MEMS) is the integration of mechanical elements, sensors, actuators, and electronics on a common silicon substrate through micro fabrication technology. MEMS is an enabling technology allowing the development of smart products, augmenting the computational ability of microelectronics In most cases, the physics behind the behavior of MEMS devices can be expressed by mathematical expressions. MEMS works by creating a mathematical model of the system and generates analytical solutions to explain the behavior of the MEMS device. The user just has to enter the input parameters like length and width of the beam for example in a user friendly GUI, and the software will immediately calculate the relevant results and plot graphs that fully explain the MEMS device or part of it. The ADXL330 is a small, thin, low power, complete 3-axis accelerometer with signal conditioned voltage outputs, all on a single monolithic IC. The product measures acceleration with a minimum full-scale range of ±3 g. It can measure the static acceleration of gravity in tilt-sensing applications, as well as dynamic acceleration resulting from motion, shock, or vibration.

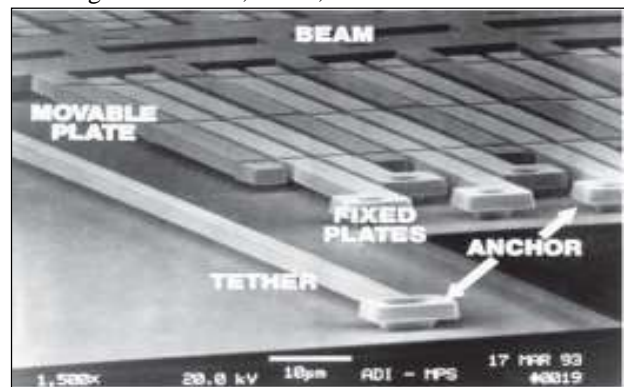

Fig 2 MEMS Accelerometer

The user selects the bandwidth of the accelerometer using the  $C_x$ ,  $C_y$ , and  $C_z$  capacitors at the  $X_{OUT}$ ,  $Y_{OUT}$ , and  $Z_{OUT}$  pins. Bandwidths can be selected to suit the application, with a



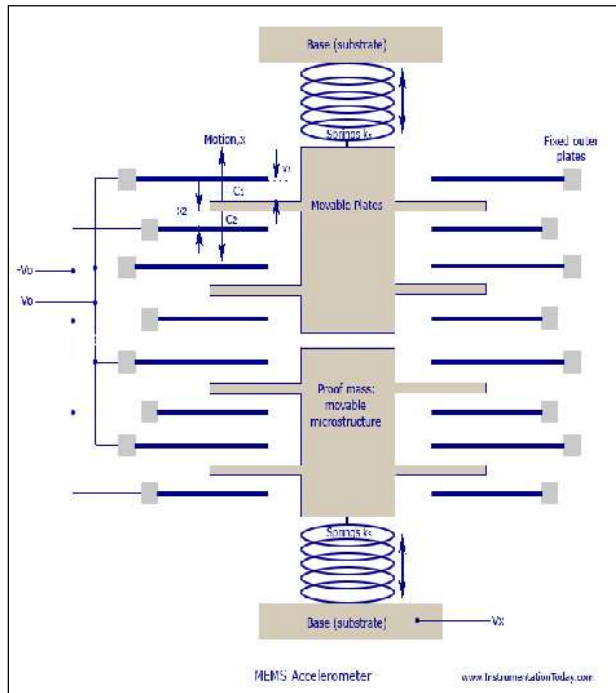

Fig 3 G-cell Accelerometer Structure

range of 0.5 Hz to 1600 Hz for X and Y axes, and a range of 0.5 Hz to 550 Hz for the Z axis.

The sensor can be modeled as a movable beam that moves between two mechanically fixed beams. Two gaps are formed; one being between the movable beam and the first stationary beam and the second between the movable beam and the second stationary beam. The ASIC uses switched capacitor techniques to measure the g-cell capacitors and extract the acceleration data from the difference between the two capacitors

**Features**

1. Gesture input for straight motion: 60 ms
2. Gesture input for directional motion (left or right): 95ms
3. Processing speed is 100kbps
4. Power consumption  
 Active mode: 47-294 Micro amperes.  
 Off mode: .4 Micro Amperes  
 Standby mode: 3 Micro Amperes
5. Cross axis Sensitivity (ability to reject an acc applied 90 deg from true axis) is  $\pm 1\%$
6. Operating voltage = 5V DC
7. Min Voltage = 19.53 mV In most micromachining technologies no or minimal additional processing is needed.
8. Max Voltage = 5 V
9. Current for x axis = 350 Micro Amperes
10. Max distance between TX and RX: 100 m

11. Speed and distance of wheelchair depends upon the battery used

12. Noise =  $\pm 1$  count

13. I2C interface speed = 400 KHz

14. Input leakage current = .025 Micro Amperes

The MEMS sensor has inbuilt I2C protocol using which the processing speed of the system is increased. Another advantage of I2C is, by using its two lines we can connect up to 128 devices to the controller. The I2C bus was designed by Philips in the early '80s to allow easy communication between components which reside on the same circuit board. The name I2C translates into "Inter IC". It is sometimes written as I<sup>2</sup>C. Simplicity and flexibility are the key characteristics that make this bus attractive to many applications.

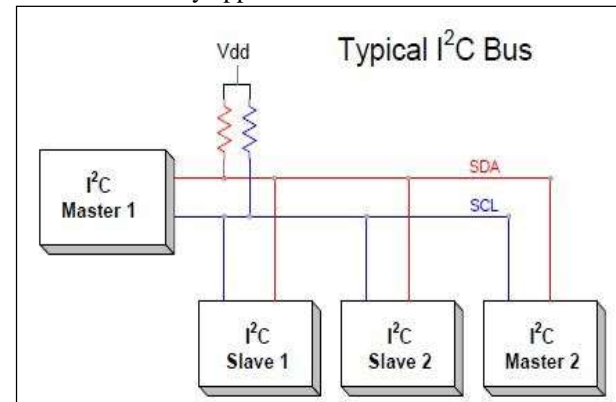

Fig 4 Digital Output

**P89v51rd2**

The AT89S52 is a low-power, high-performance CMOS 8-bit microcontroller with 8K bytes of in-system programmable Flash memory. The device is manufactured using Atmel's high-density nonvolatile memory technology and is compatible with the industry-standard 80C51 instruction set and pinout. The on-chip Flash allows the program memory to be reprogrammed in-system or by a conventional nonvolatile memory programmer. By combining a versatile 8-bit CPU with in-system programmable Flash on a monolithic chip, the Atmel AT89S52 is a powerful microcontroller which provides a highly-flexible and cost-effective solution to many embedded control applications. The AT89S52 provides the following standard features: 8K bytes of Flash, 256 bytes of RAM, 32 I/O lines, Watchdog timer, two data pointers, three 16-bit timer/counters, a six-vector two-level interrupt architecture, a full duplex serial port, on-chip oscillator, and clock circuitry. In addition, the AT89S52 is designed with static logic for operation down to zero frequency and supports two software selectable power saving modes. The Idle Mode stops

the CPU while allowing the RAM, timer/counters, serial port, and interrupt system to continue functioning. The Power-down mode saves the RAM contents but freezes the oscillator, disabling all other chip functions until the next interrupt or hardware reset.

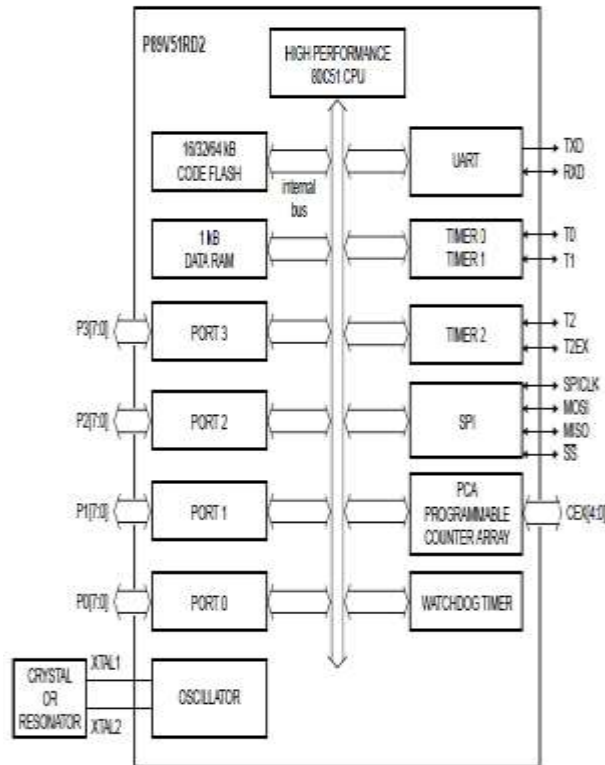

Fig 5 Microcontroller Block Diagram

A key feature of the P89V51RD2 is its X2 mode option. The design engineer can choose to run the application with the conventional 80C51 clock rate (12 clocks per machine cycle) or select the X2 mode (six clocks per machine cycle) to achieve twice the throughput at the same clock frequency. It has four 8-bit I/O ports with three high-current port 1 pins (16 MA each). Some other features are:

- 1) Three 16-bit timers/counters;
- 2) Programmable watchdog timer;
- 3) Eight interrupt sources with four priority levels;
- 4) Second DPTR register;
- 5) Low EMI mode (ALE inhibit);
- 6) TTL- and CMOS-compatible logic levels.

**Proposed Model**

There are two essential characteristics for any effective GSR system: accuracy and speed. In addition, to meeting these demands, GR systems face a number of additional challenges including the large

variance that exists individual human hand patterns (e.g. tracking, motion, variation). A successful GR system requires extraordinary flexibility to accommodate these variances. The process of GRS typically follows these steps:

1. Hand gesture is captured by an Accelerometer sensor and undergoes analog-to-digital conversion.
2. Different Gestures are converted into signal features that can be used by microcontroller.
3. Series of different gestures are compared to saved information, the result shown on the LCD screen in the 3 Co-ordinates(X,Y,Z). LCD shows the numerical values which will be helpful to know about the position of hand.
4. For serial transmission the encoder is used and the RF Transmitting antenna is used with 433MHZ frequency.
5. At the receiver side the An H bridge is built with four switches (solid-state or mechanical). When the switches S1 and S4 (according to the first figure) are closed (and S2 and S3 are open) a positive voltage will be applied across the motor. By opening S1 and S4 switches and closing S2 and S3 switches, this voltage is reversed, allowing reverse operation of the motor.
6. The wheelchair is operated due to the Dc motor, the motor drives by the H-Bridge switching conditions. We need two H-Bridge and one H-Bridge has four Transistor for motor operation as shown in the receiver circuit Fig 7. The four conditions on which the motor movement based are

| S1 | S2 | S3 | S4 | Result              |
|----|----|----|----|---------------------|
| 1  | 0  | 0  | 1  | Motor moves Right   |
| 0  | 1  | 1  | 0  | Motor moves Left    |
| 0  | 0  | 0  | 0  | Motor Stop          |
| 0  | 1  | 0  | 1  | Motor Moves forward |
| 1  | 0  | 1  | 0  | Motor moves Back    |

Table 2 Switching Binary Conditions

The circuit diagram for both the phases of the system with all detail and the explanation of the component is discussed earlier.

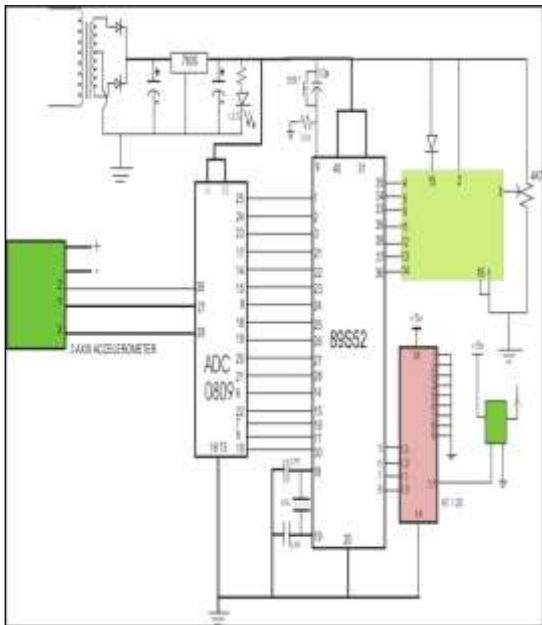

Fig 6 Transmitter Circuit

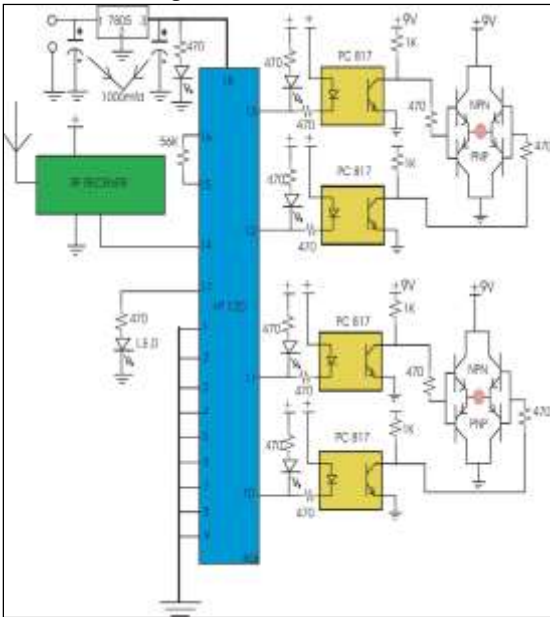

Fig 7 Receiver Circuit

**Results and discussion principles**

By using above procedure hardware setup is done figure 8 shows input part that is interfacing of gesture recognition module and accelerometer to CMOS 089C52 controller. A working model of Accelerometer based gesture recognition system was successfully made for the movement of the wheelchair .It was prepared with the help of 89C52 microcontroller (8051 family), two DC motors and other necessary equipments which resulted in the

proper movement of the Wheelchair in all the four directions i.e. forward, backwards, right, left and stop.



Fig 8 Hand gesture and Co-ordinates value

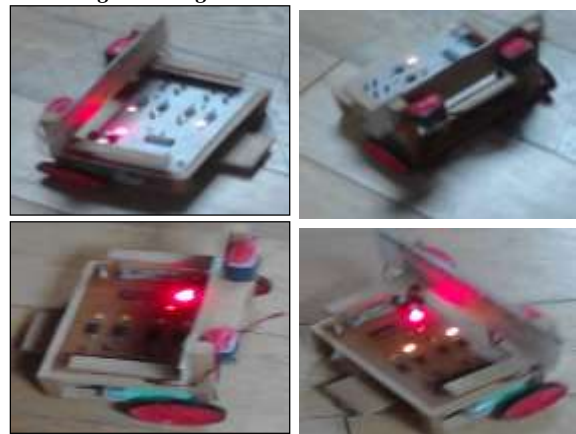

Fig 9 Hardware Setup Output Part

- (a) Forward movement (b) Left movement (c) Back Direction  
(d) Right movement

**Observations**

| Observation | No. of trials | No. of Successful Outcomes | Accuracy     |
|-------------|---------------|----------------------------|--------------|
| Forward     | 15            | 14                         | 96.67        |
| Left        | 15            | 12                         | 93.33        |
| Right       | 15            | 13                         | 93.33        |
| Backward    | 15            | 14                         | 96.67        |
| Stop        | 15            | 14                         | 96.67        |
|             |               | <b>Overall Accuracy</b>    | <b>95.33</b> |

**Conclusion**

Accelerometers have a secure place in the movement of equipment based on actions done. The system can be made free from challenges and will be cost effective in the near future. Calibration though at times is problem but with more introspection and research better calibration and performance can be achieved. The system developed by us despite calibration errors and problems still is able achieve accuracy of 88-95%, further improvements can used to achieve an accuracy of 95-99%. The system proves a very competitive performance computationally and in terms of recognition accuracy. Interesting topic to research is the problem of tilting. As mentioned earlier, tilting of the remote can lead to erroneous recognition if not taken into account. Therefore, in our proposed system, subjects were requested to hold the remote in a natural way while performing the gestures and to avoid any tilting of the remote as much as possible. However, this way of holding the remote can result in some inconvenience to users of the system. Consequently, a system which is immune to tilting of the accelerometer is definitely a desirable one.

**Acknowledgements**

The author wish to thank Mr. B.Anil Kumar for motivating me to do such an interesting work , Incharge and Prof. Shashi Kumar Singh , School of EEE, Lingaya's University, Faridabad for their moral support through the work.



**References**

1. Amundson JS, Amundson SG, "A joystick controlled wheelchair", Biomed Sci Instrum .1991; 27:131-3.
2. 2007 4th international conference on Electrical and Electronics Engineering

- (ICEEE 2007) Mexico City, Mexico.September 5-7, 2007
3. [http://mafija.fmf.unilj.si/seminar/files/2007\\_2008/MEMS\\_accelerometers-koncna.pdf](http://mafija.fmf.unilj.si/seminar/files/2007_2008/MEMS_accelerometers-koncna.pdf)
4. <http://en.wikipedia.org/wiki/Accelerometer>
5. Gesture Recognition System @2010International Journal Of Computer Applications(0975-8887)Volume 1-No. 5.
6. J.S. Kim, C.S. Lee, K.J. Song, B. Min, Z. Bien, "Real-time hand gesture recognition for avatar motion control," Proceedings of HCI'97, pp. 96-101,February 1997
7. F. Arce, J. M. G. Valdez," Accelerometer-Based Hand Gesture Recognition Using Artificial Neural Networks" in Soft Computing for Intelligent Control and Mobile Robotics Studies in Computational Intelligence, vol. 318, pp 67-77, 2011
8. "Luigi Lamberti and Francesco Camastra", Real-Time Hand Gesture Recognition using a Color Glove," Department of Applied Science, University of Naples Parthenope, 2010, pp.321-344
9. A. Pandit , D. Dand , S. Mehta , S. Sabesan , A. Daferiy," A Simple Wearable Hand Gesture Recognition Device using iMEMS," International Conference of Soft Computing and Pattern Recognition , pp 592-597,2009
10. R. Wang, J. Popovic, "Real-time hand-tracking with a color glove," ACM Transactions on Graphics, vol. 28, pp 461-482 , 2009
11. "Vision Based Hand Gesture Recognition For Computer Interaction: A Survey" By Anupam Agarwal And SiddharthS.Rautaray In Springer Science +Business Media Dordrecht 2012, ArtifIntellRev, DOI 10.1007/S 10462-012-9356-9
12. "An Approach To Glove-Based Gesture Recognition" FaridParvini, Dennis Mcleod, Cyrus Shahabi, Bahareh Navai, Baharak Zali, Shahram Ghandeharizadeh Computer Science Department University Of Southern California Los Angeles, California 90089-0781 [Fparvini, Mcleod, Cshahabi, Navai, Bzali, Shahram] @Usc.Edu.



### Author Bibliography

|  |   |
|--|---|
|   | <p><b>Manisha Chahal</b> received her B.Tech in Electronics and Communication from M.D. University, Rohtak in 2012. She is currently pursuing M.tech from Lingaya's University, Faridabad, Haryana, India. Her research interests include Image Processing, Artificial Intelligent Networks and Computer Vision. She has many no. of research paper in different International journals.</p>  |
|  | <p><b>B. Anil Kumar</b> received B. Tech degree in Electrical and Electronics Engineering in 2008 from Lakireddy Balireddy College of Engineering Mylavaram Andhra Pradesh, India and received his M.tech degree in power System in 2012 from National Institute of Technology Hamirpur India. He has worked as Asst. Professor in Department of ECE/EE in Lingays GVKS IMT. He currently pursuing Ph.D from IIT Rourkee, Uttrakhand. He has many no. of research papers in different International Journals and IEEE Conferences</p> |